



IRIS 330/330S

USER MANUAL

1. Specifications
2. Chassis Parts
3. Control Panel Functions
4. Remove The Front Panel Instructions
5. 3.5"/2.5" HDD/SSD Installation
6. Cooling System Installation
7. Digital RGB Fan Installation For Motherboard
8. RF Remote (2020 New Version)

Specifications

Model	
Model Name	IRIS 330
Model Number	CSAZ-330
Specifications	
Type	ATX Mid Tower
Color	Black(exterior)/black(interior)
Side Panel Window	Left Side panel: Tempered Glass with rubber mounts
Max CPU Cooler Height	UP to 155mm
Max Video Card Length	Up to 380mm long video card
Power Supply	Not Included
Motherboard Compatibility	ATX
Expansion	
External 5.25" Drive Bays	0
Internal 2.5" Drive Bays	Up to 3
Internal 3.5" Drive Bays	Up to 2
Expansion Slots	7
Top Ports	Power button, Reset button, HD Audio, USB 3.0 x 1, USB2.0x2
Physical Specifications	
Case Dimension (HxWxD)	447x216x440mm/17.6 x 8.5 x 17.3 inches
Weight	5.49kg /12.1lbs
Features	
Tempered Glass Sides Window	High-quality tempered glass side window allows for clear visuals to inner components
Addressable RGB Light Effects	Addressable RGB light strips on the front panel and side port location, all controlled by RF Remote (2020 New version) ※ Without RF REMOTE before 2020 version, controlled by motherboard.
Available Fan Ports	3x120mm Fan ports in the front (2x120mm Digital RGB Fan included) 2x120mm Fan ports on the top 1x120mm Fan port in the rear 2x120mm Fan ports on the top of PSU chamber
Water Cooling	Supports radiators up to 240/360mm in the Front
Dust filters	Removable (magnetic) dustproof net on the top, iron net on bottom of chassis.
Power Supply Support	Bottom mounted ATX Power Supply

Specifications

Model	
Model Name	IRIS 330S
Model Number	CSAZ-330S
Specifications	
Type	ATX Mid Tower
Color	Black(exterior)/black(interior)
Side Panel Window	Left Side panel: Tempered Glass with rubber mounts
Max CPU Cooler Height	UP to 155mm
Max Video Card Length	Up to 340mm long video card
Power Supply	Not Included
Motherboard Compatibility	ATX
Expansion	
External 5.25" Drive Bays	0
Internal 2.5" Drive Bays	Up to 4
Internal 3.5" Drive Bays	Up to 2
Expansion Slots	7
Top Ports	Power button, Reset button, HD Audio, USB 3.0 x 1, USB2.0x2
Physical Specifications	
Case Dimension (HxWxD)	447x216x402mm/17.6 x 8.5 x 16 inches
Weight	5.16kg /11.4lbs
Features	
Tempered Glass Sides Window	High-quality tempered glass side window allows for clear visuals to inner components
Addressable RGB Light Effects	Addressable RGB light strips on the front panel and side port location, all controlled by RF Remote (2020 New version) ※ Without RF REMOTE before 2020 version, controlled by motherboard.
Available Fan Ports	3x120mm Fan ports in the front (2x120mm Digital RGB Fan included) 2x120mm Fan ports on the top 1x120mm Fan port in the rear
Water Cooling	Supports radiators up to 240/360mm in the Front
Dust filters	Removable (magnetic) dustproof net on the top, iron net on bottom of chassis.
Power Supply Support	Bottom mounted ATX Power Supply

CSAZ-330

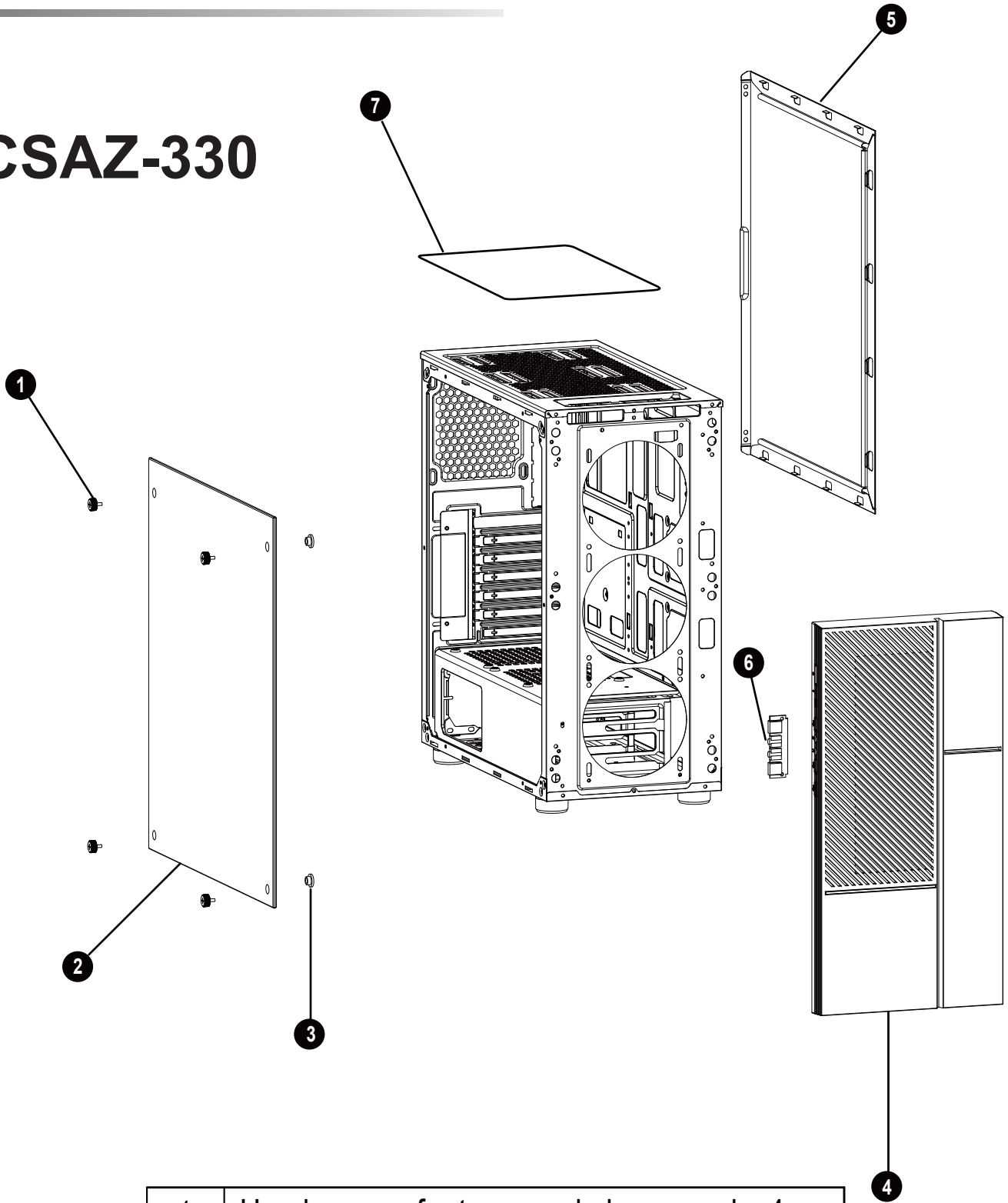

1	Hand screws for tempered glass panel x 4
2	Left side tempered glass panel
3	Rubber gasket x 4
4	Front panel
5	Right side metal panel
6	I/O ports
7	Removable (magnetic) dust proof net

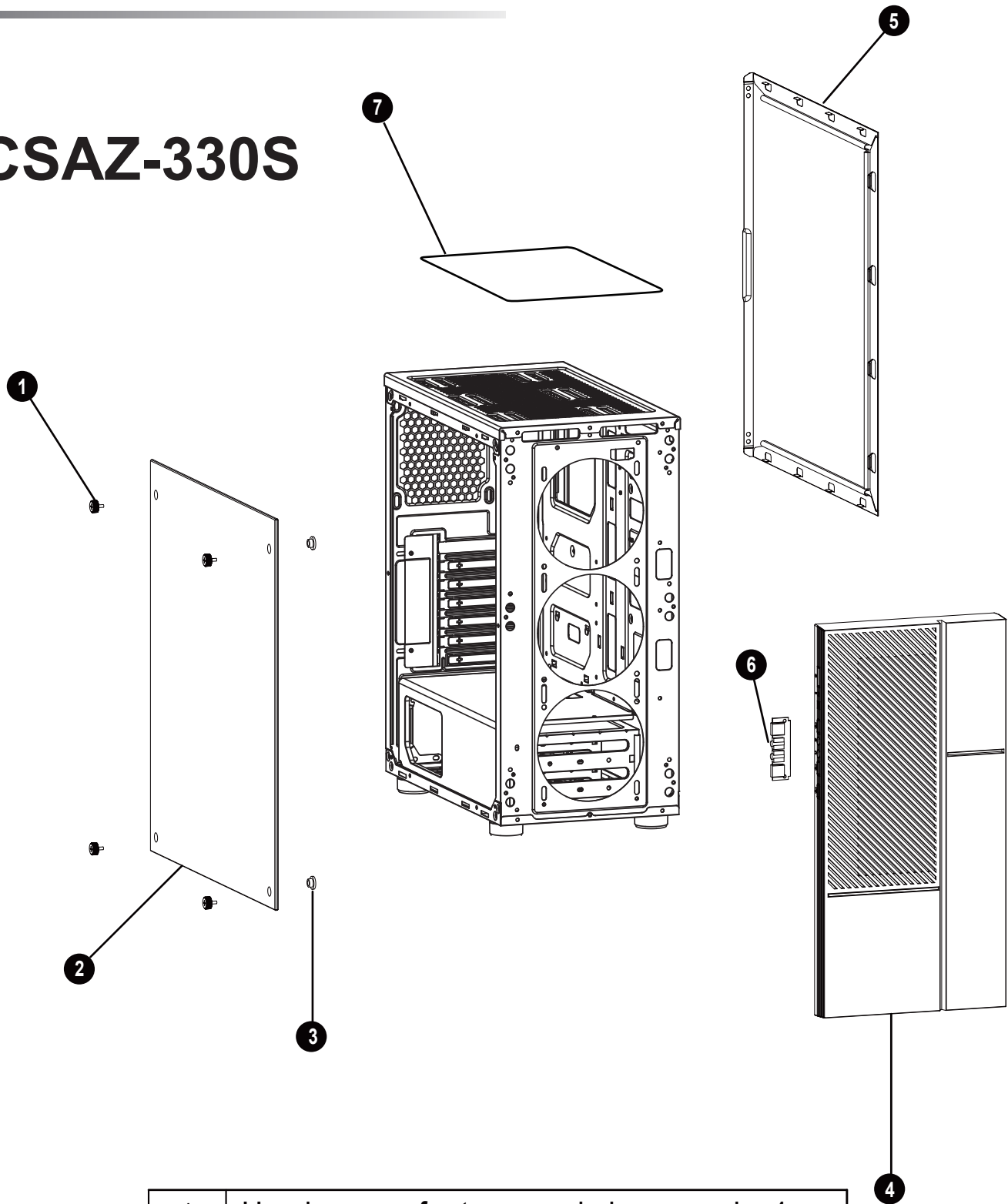

CSAZ-330S



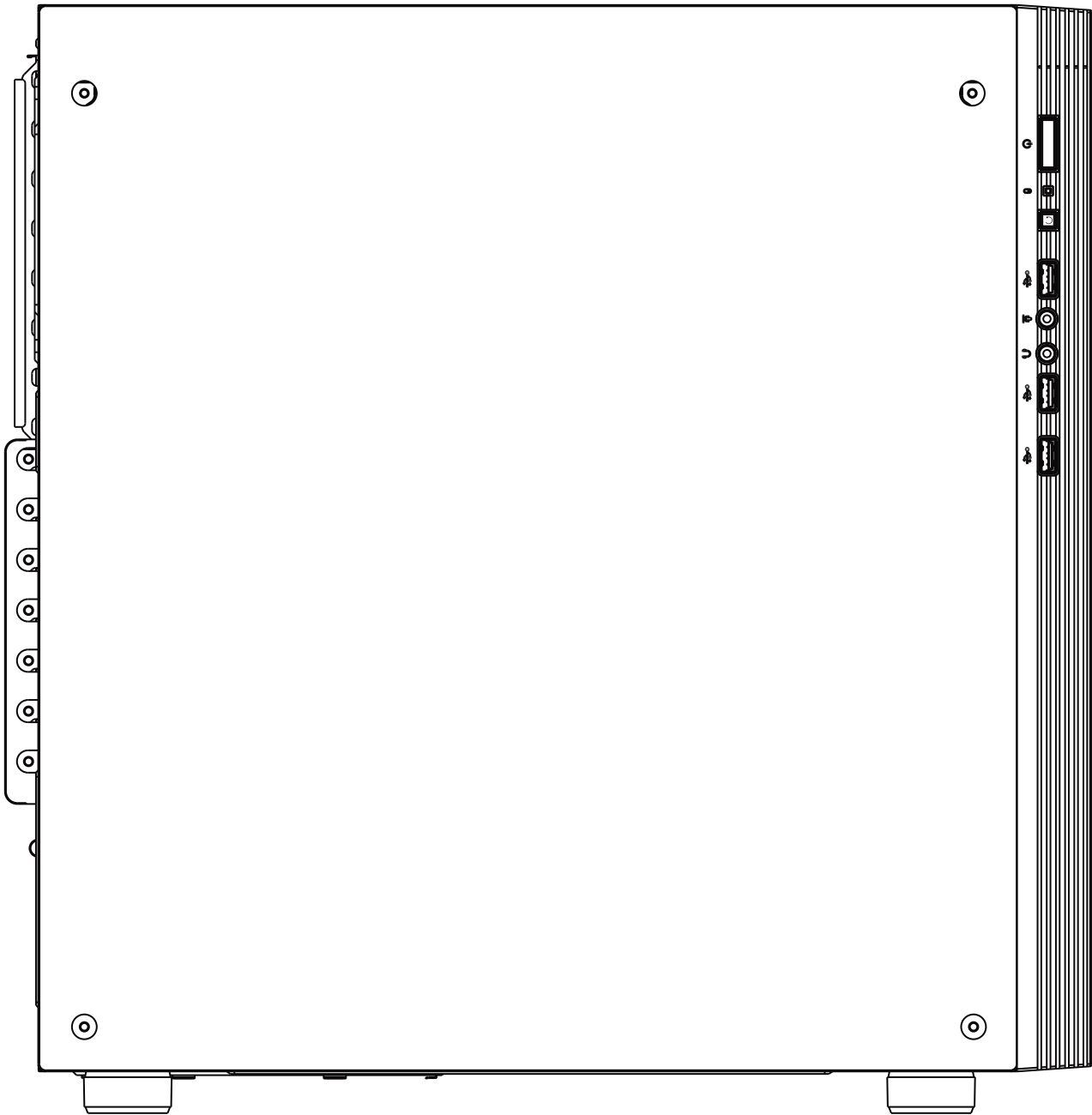

1	Hand screws for tempered glass panel x 4
2	Left side tempered glass panel
3	Rubber gasket x 4
4	Front panel
5	Right side metal panel
6	I/O ports
7	Removable (magnetic) dust proof net

Control panel functions



	Power
	Reset
	USB 2.0

	USB 3.0 (Blue)
	Mic
	Audio

Remove The Front Panel Instructions

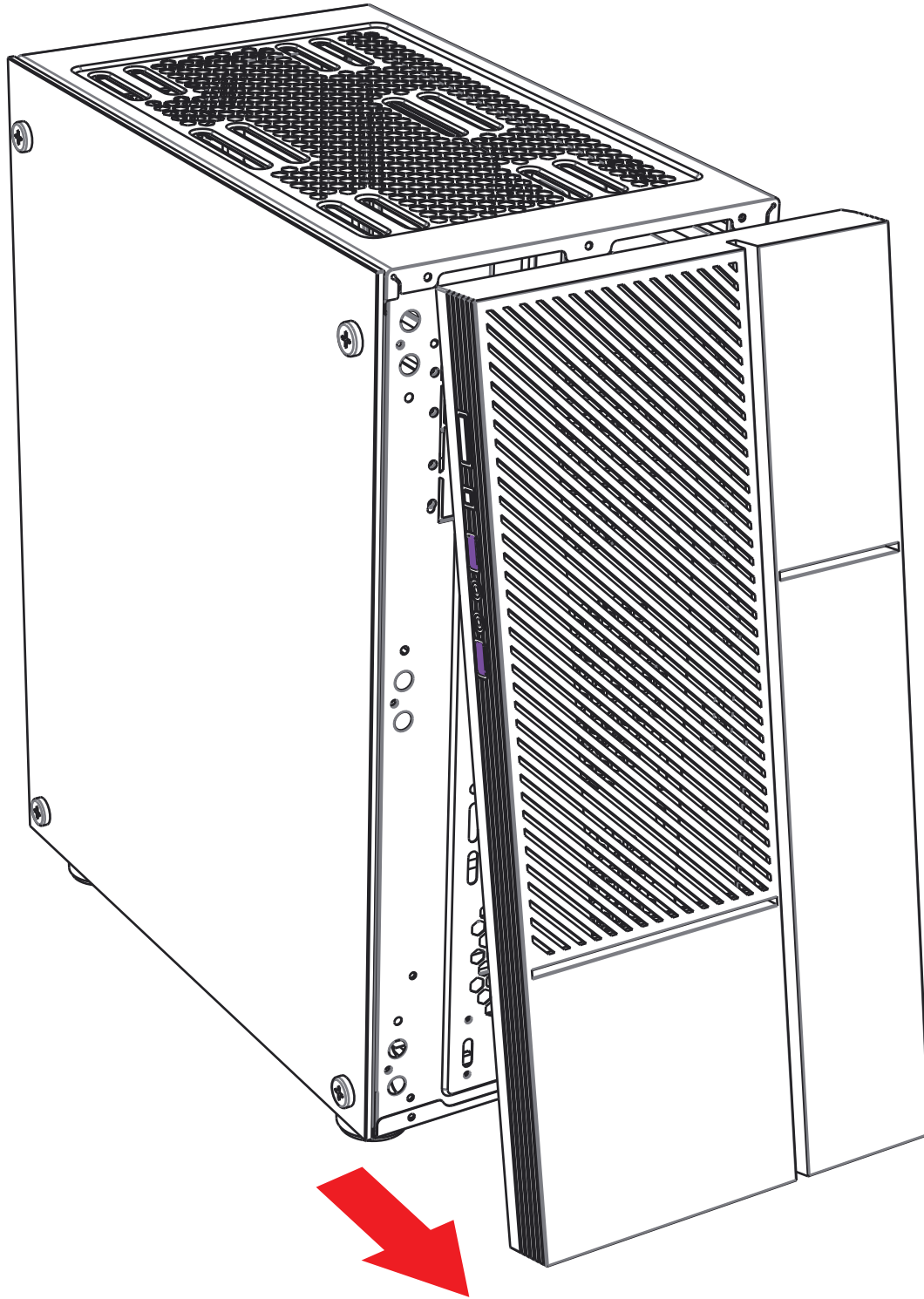

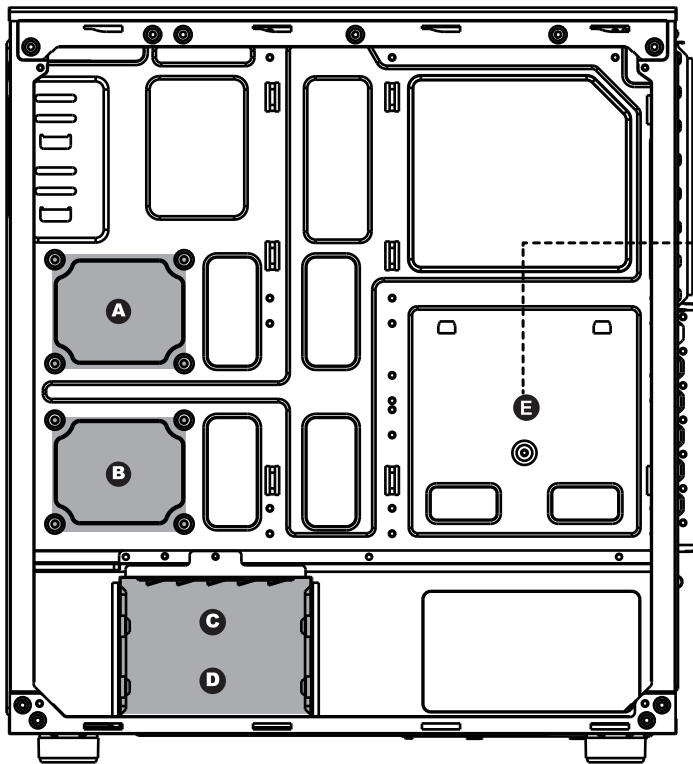
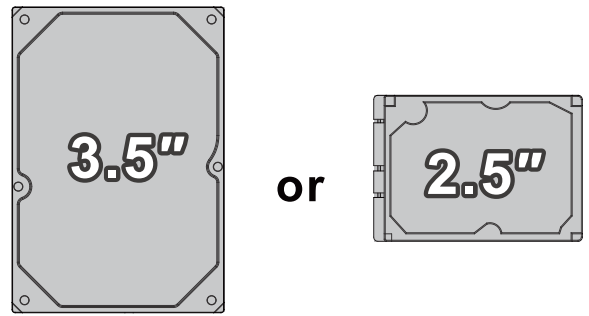
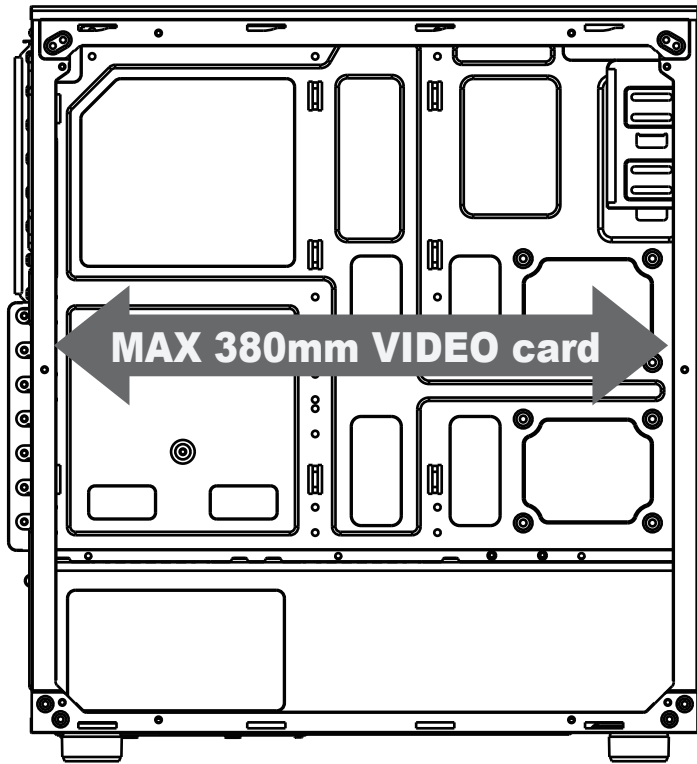

2.5" SSD Installation

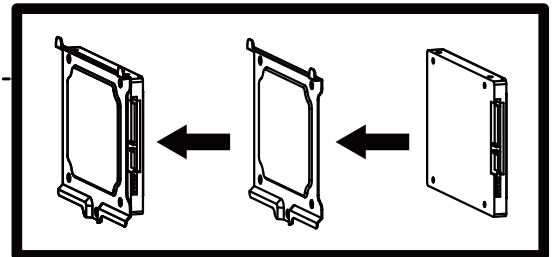

- Two mounting holes support 2.5" devices. (A B E)
- Support mounting 3.5" HDD with slide rail screws. (C D)

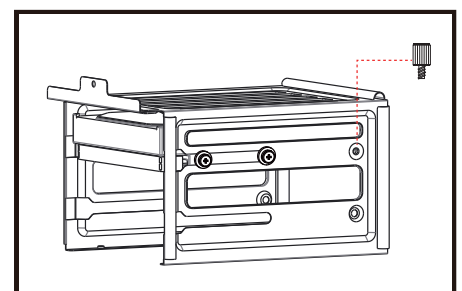
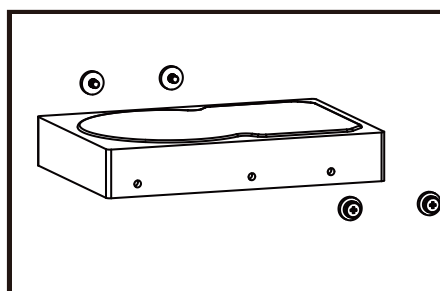
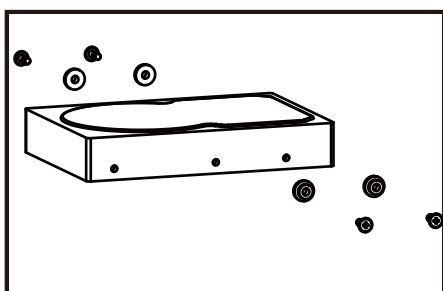

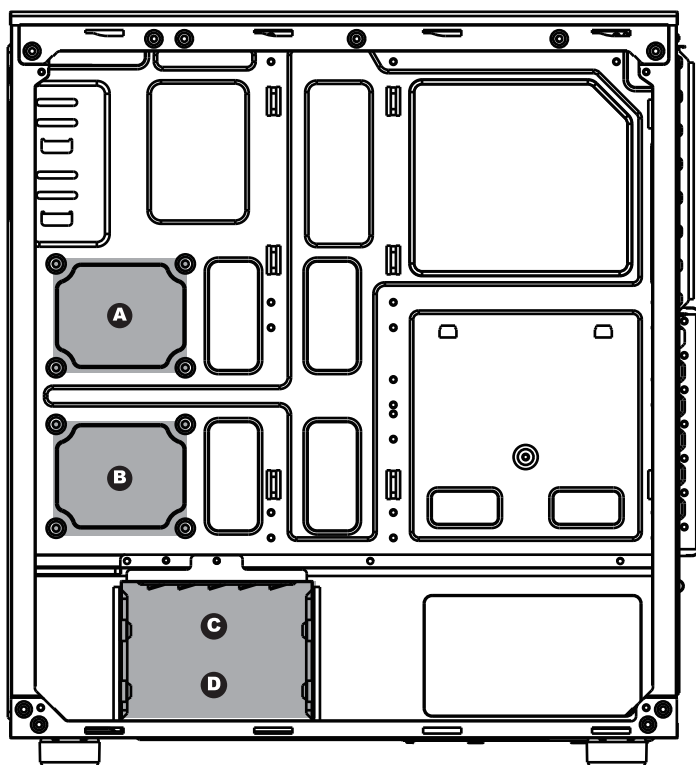
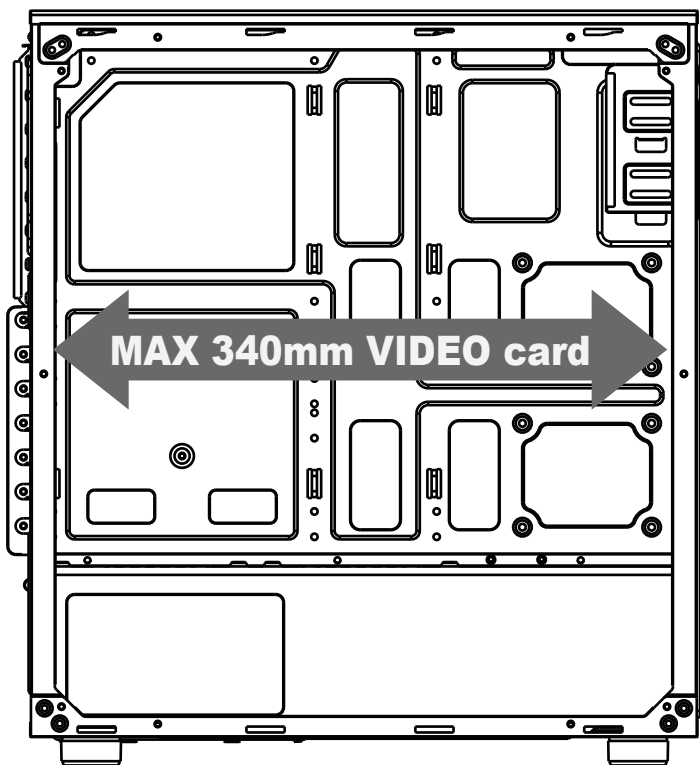

or



- Two mounting holes support 2.5" devices. (A B)
- Two multifunctional trays support 3.5" HDD or 2.5" SSD. (C D)

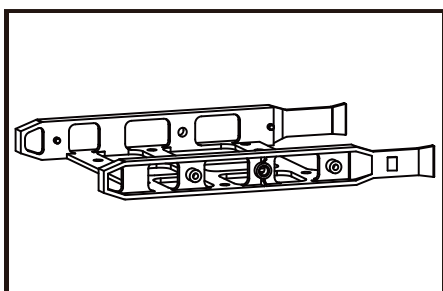

Multifunctional bracket.

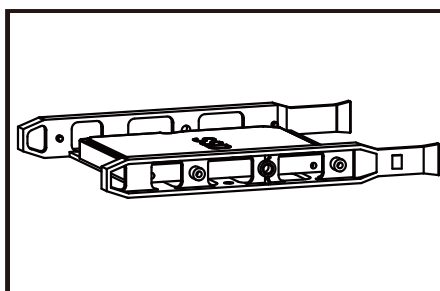

Secure 2.5" SSD / HDD with screws.

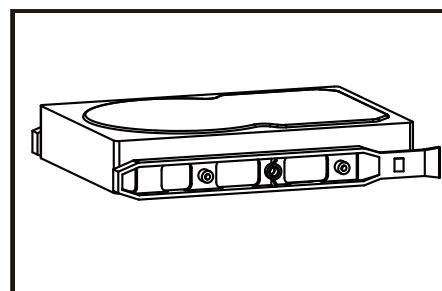

Secure 3.5" HDD with screws.

CSAZ-330

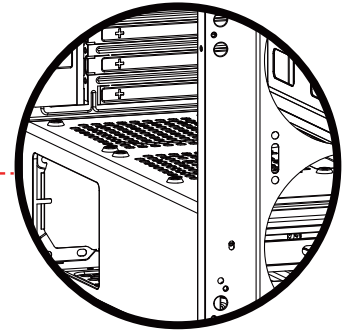
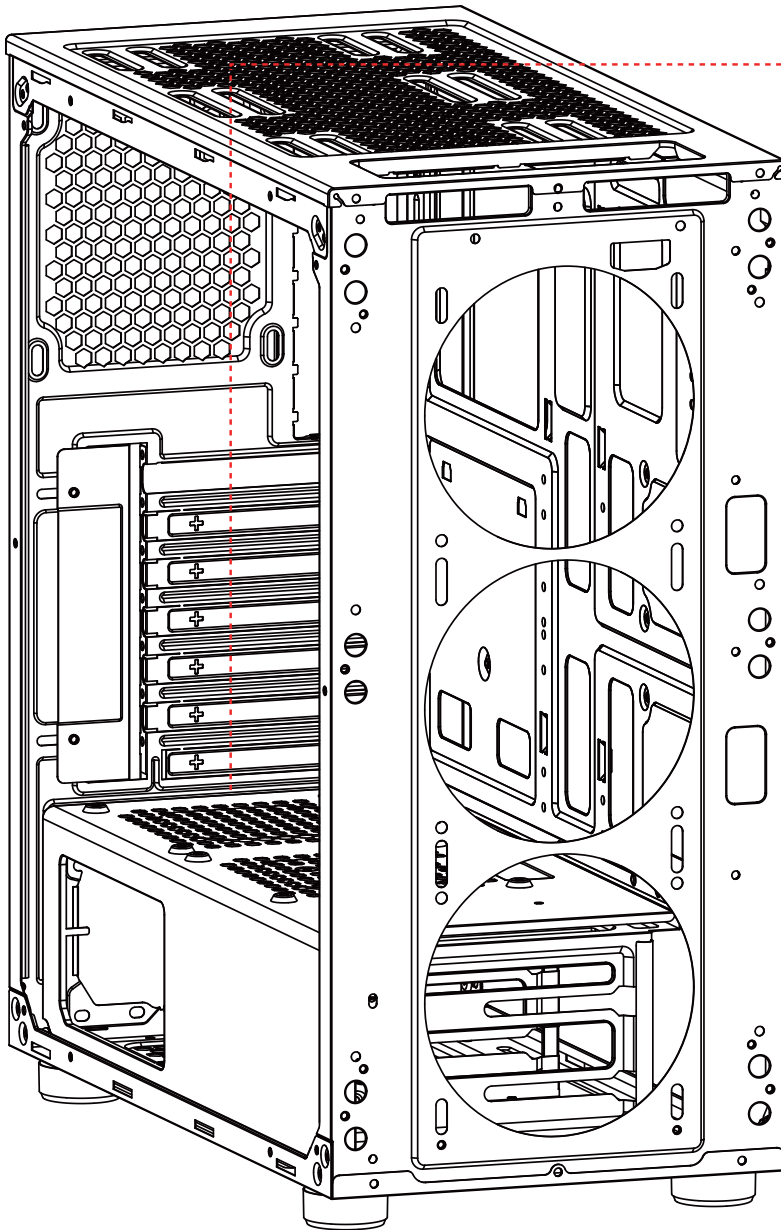

•2x120mm Fan ports on the top of PSU chamber.

120mm x2

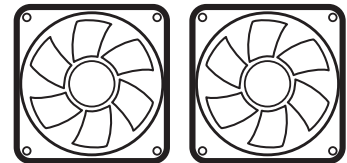

Front

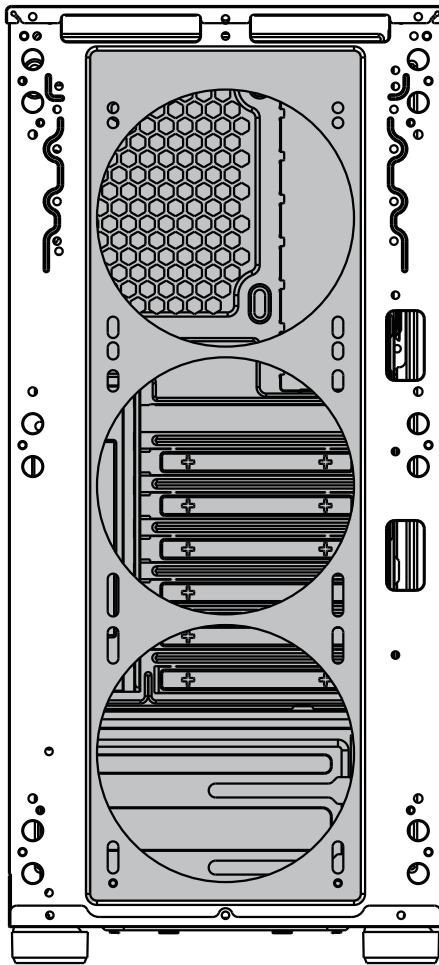
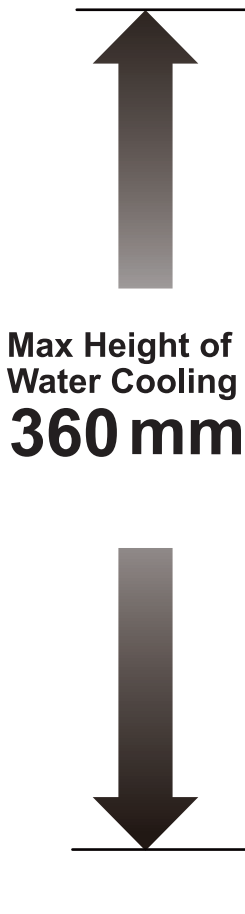

120mm x3

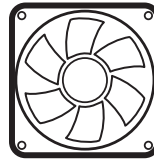
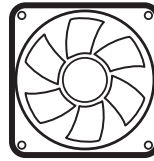
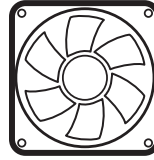

Top

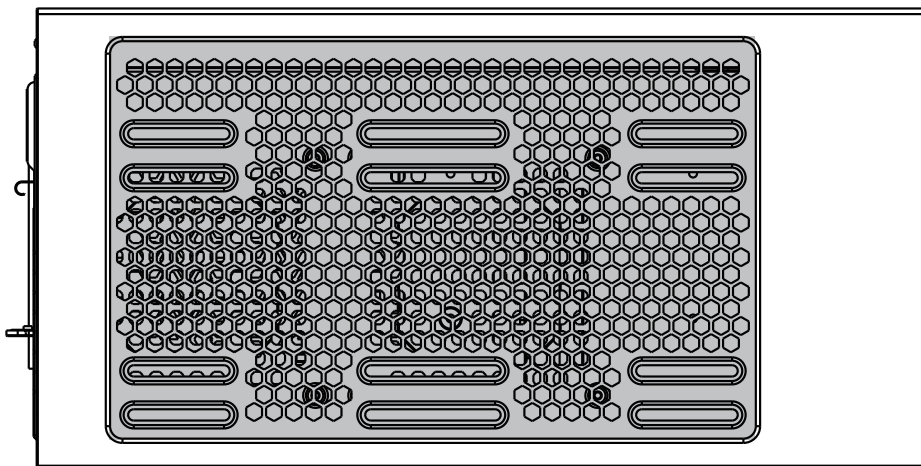

120mm x2

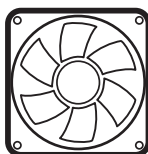
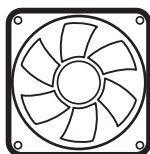

Move HDD cage to install the fan on the front panel

Move HDD cage to install the Radiator and fan on the front panel

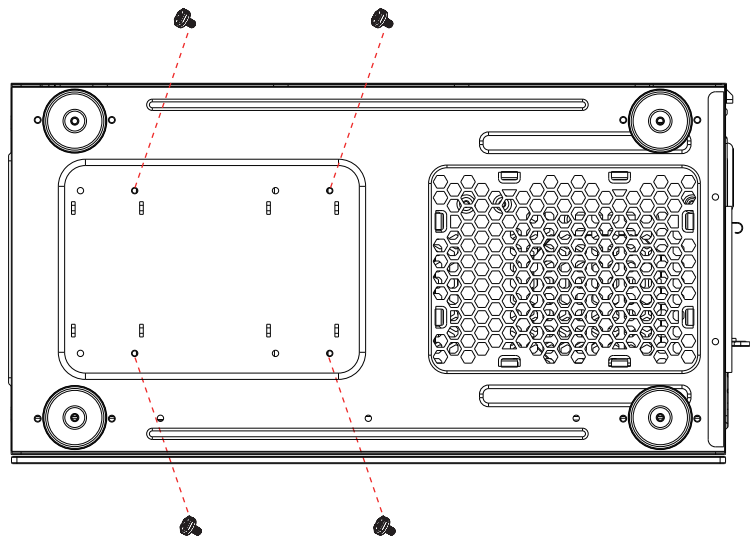
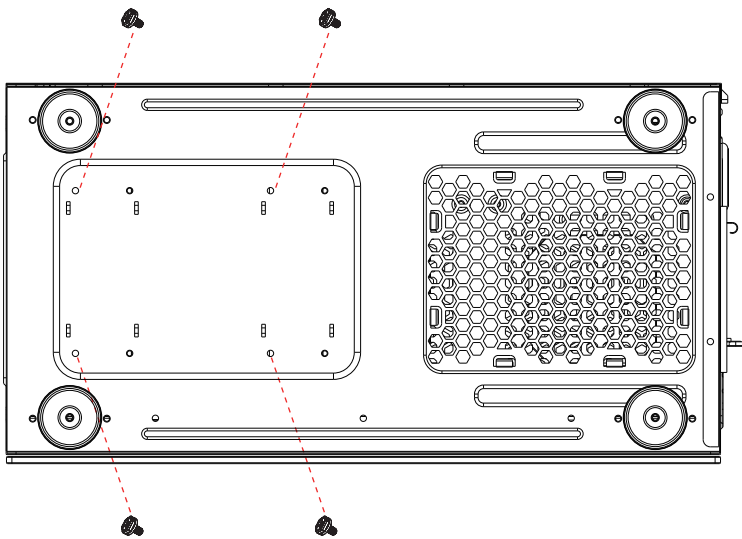
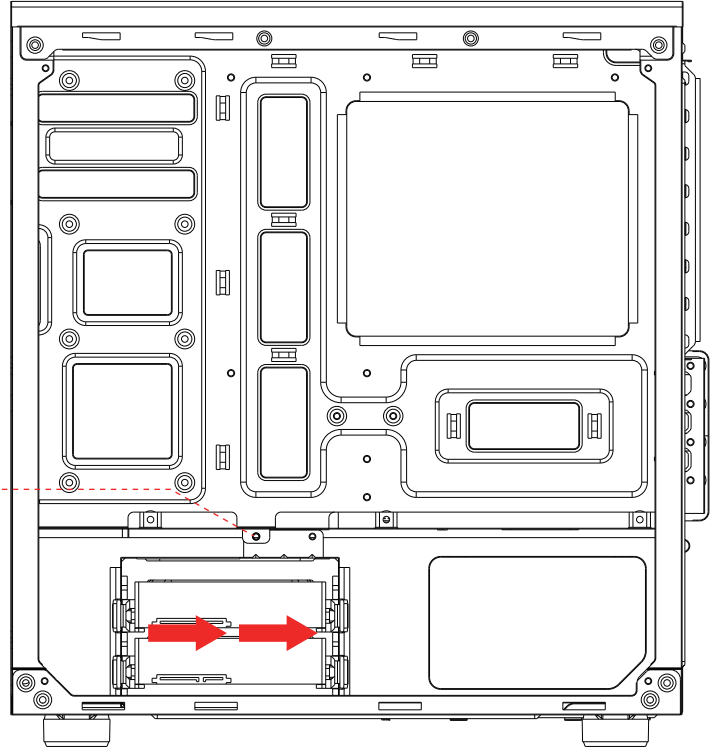
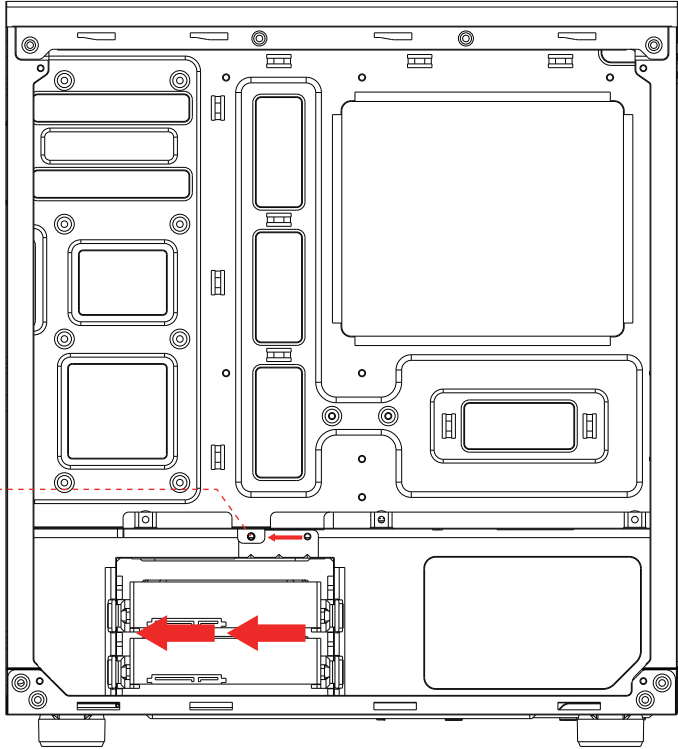

Move HDD cage to install the fan on the front panel

Move HDD cage to install the Radiator and fan on the front panel

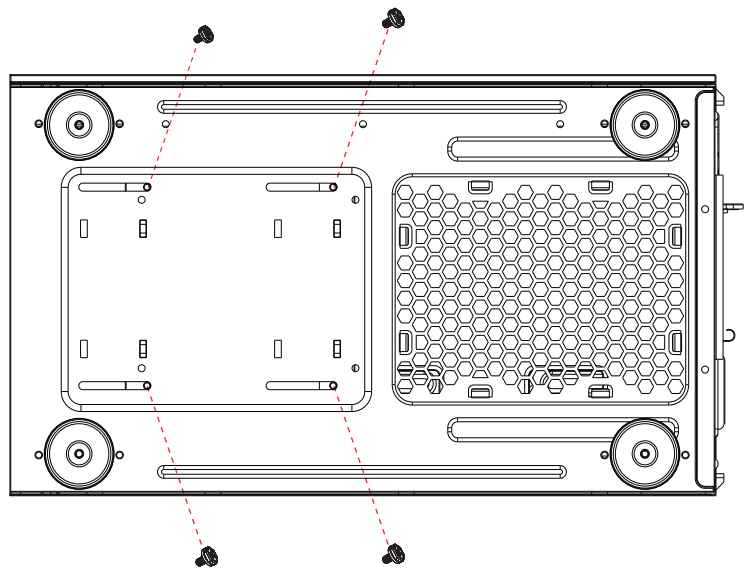
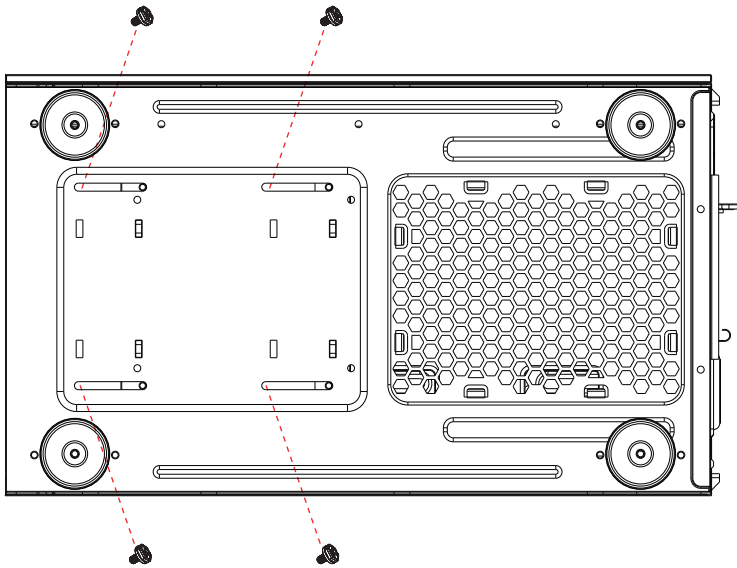
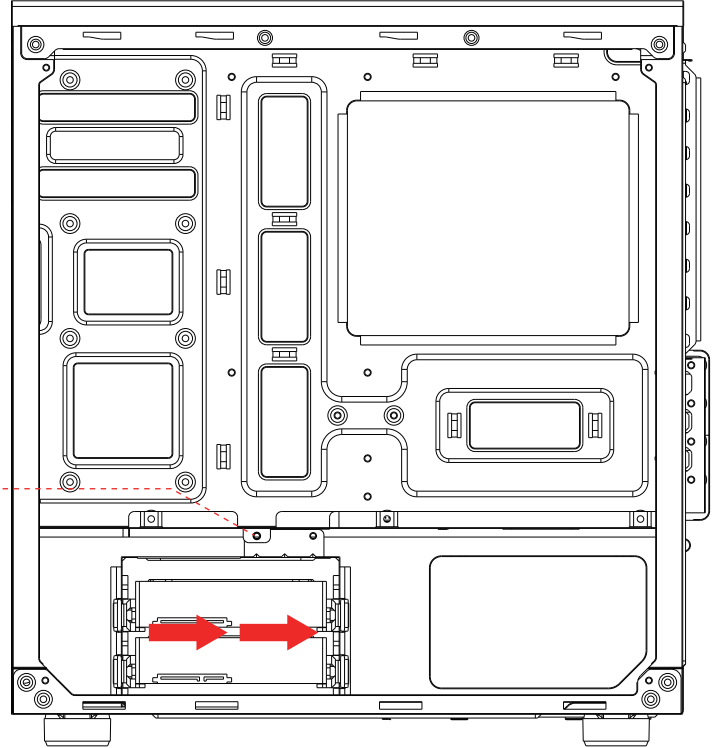
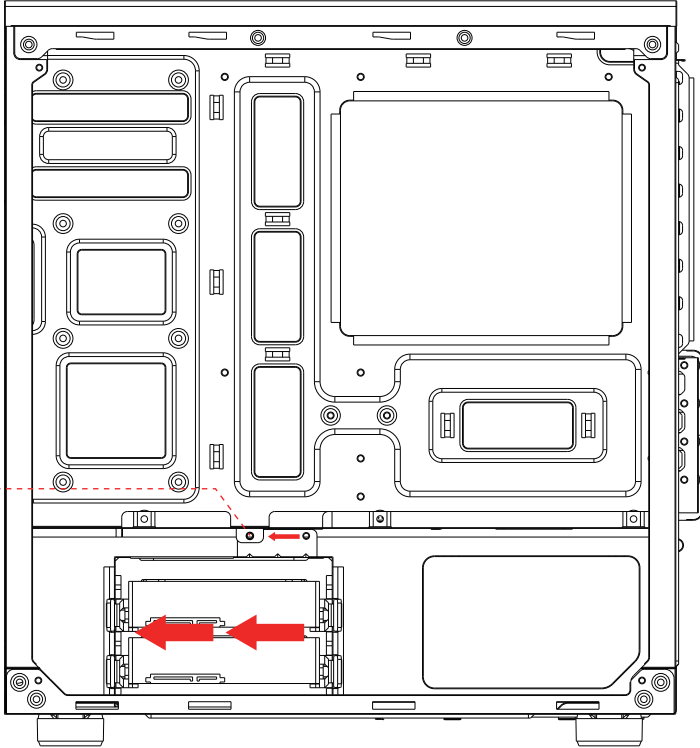

Digital RGB fan installation for motherboard

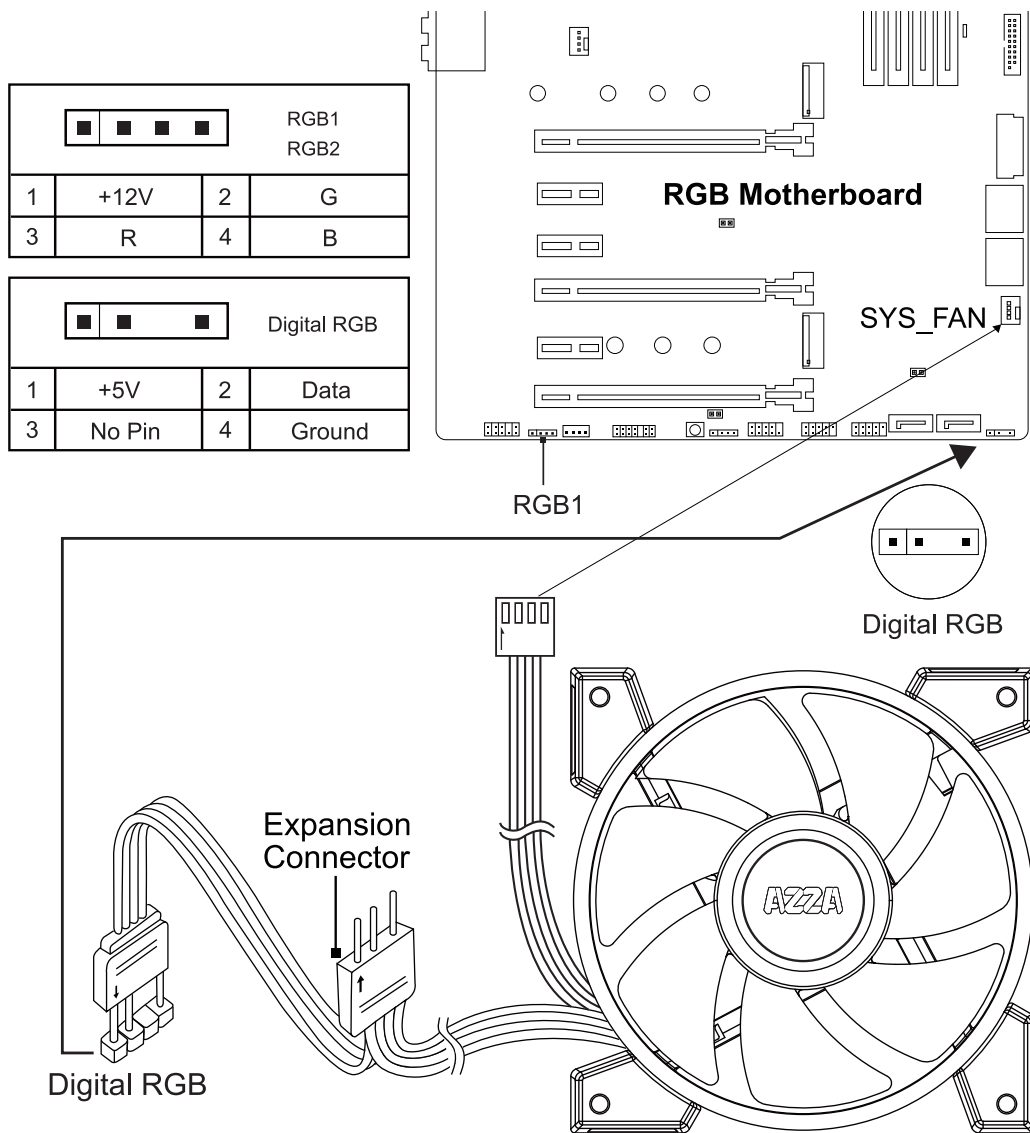

The addressable RGB fans can connect directly to the 5V addressable RGB headers of compatible motherboards, such as those from MSI™, ASUS™, Gigabyte™ and AsRock™.

Please note: Only 5V addressable headers from compatible motherboards are supported. Please do NOT connect the fan to a 12V non-addressable header.

Please check your motherboard's specifications before use. Do not go past the motherboard's allowed limits on power rating and LED count when connecting multiple fans/LED strip

RF Remote (Model Number: RF-DRGB-I366) (2020 New Version)

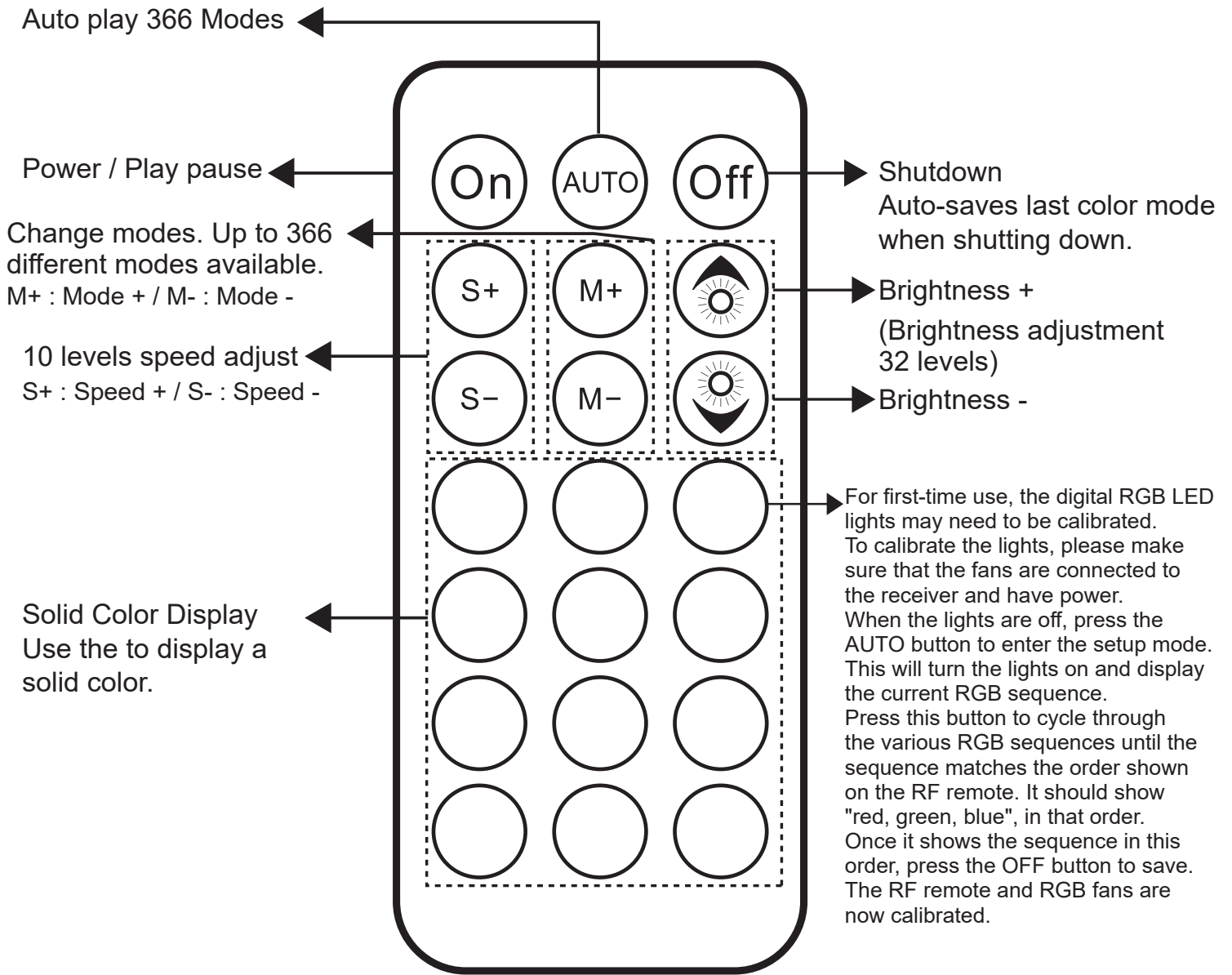

The first Digital RGB fan is to be connected to the Digital RGB LED RF remote in the chassis, while the rest of them can be daisy chained to the first one with their own male and female plugs.

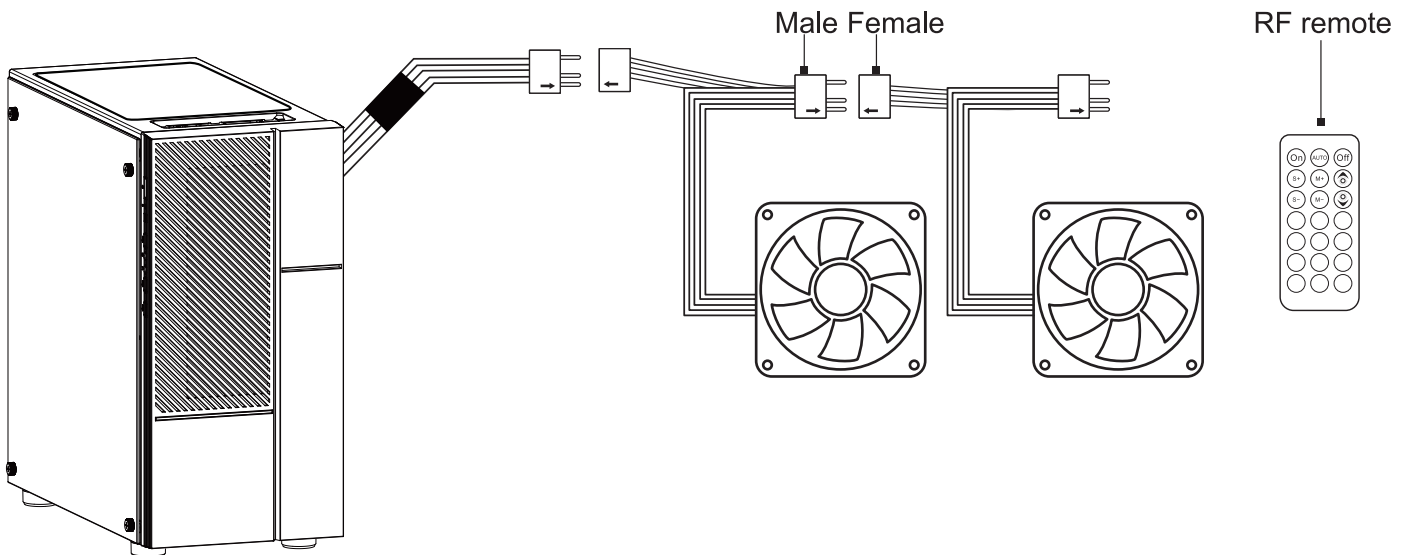

AZZA
ONE VISION. ONE MISSION